

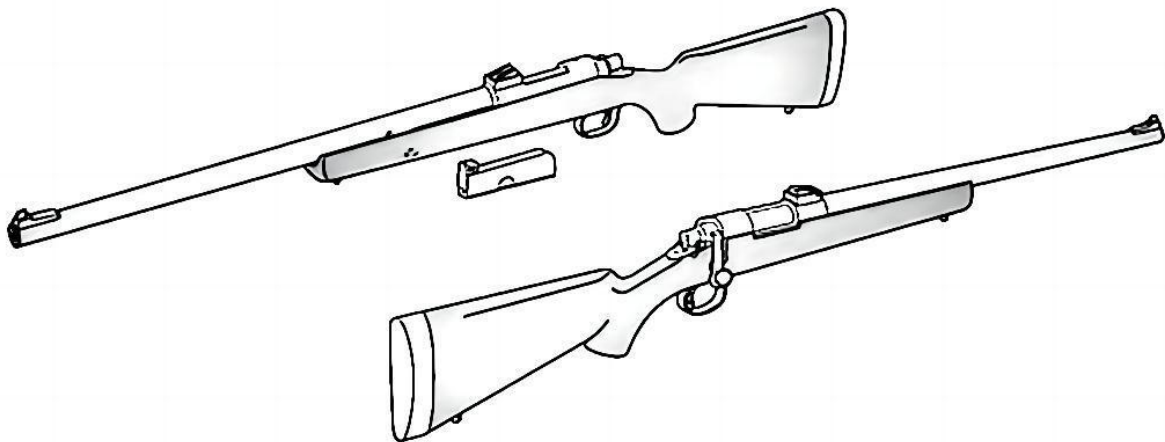

VSR-10 SERIES
(SPING SINPER RIFLE)

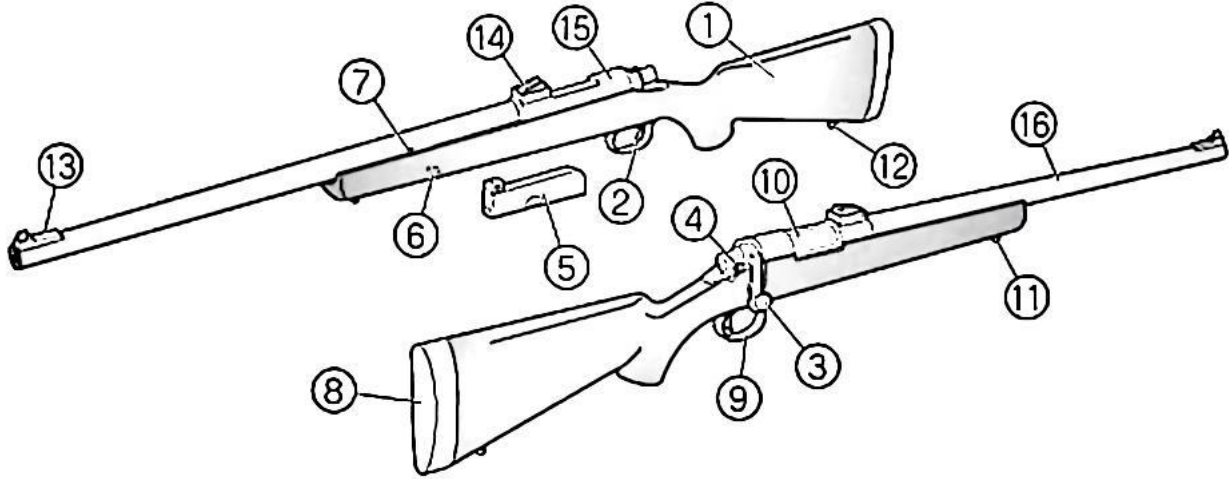

1-NAME OF PARTS



No.	NAME	No.	NAME	No.	NAME
1.	Stock	7.	Hop Adjustment lever	13.	Front Sight
2.	Trigger	8.	Butt Plate	14.	Rear Sight
3.	Bolt Handle	9.	Trigger Guard	15.	Receiver Assy
4.	Safety lever	10.	Cylinder Assy	16.	Outer Barrel
5.	Magazine	11.	Front Sling Pin		
6.	Magazine Catch Button	12.	Rear Sling Pin		

2-SAFETY SETTING

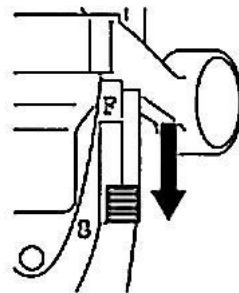
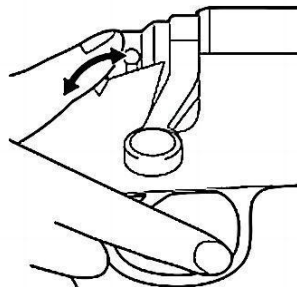
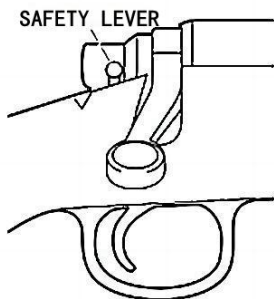

SAFE POSITION

When you are not firing the gun or during storage. Always set the selector to the Safe position and attach the protective cap.

-Always set the safety lever to SAFE until immediately before firing

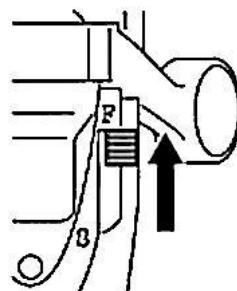

FIRE POSITION

The gun will fire one shot each time the trigger is pulled

3-SETTING THE MAGAZINE

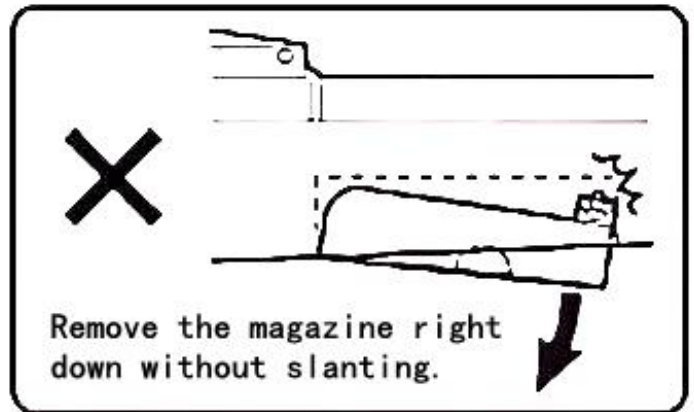
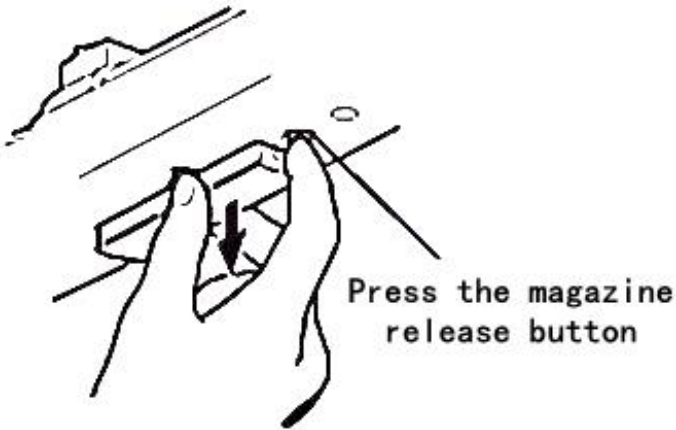

1. Press the magazine release button to remove the magazine.

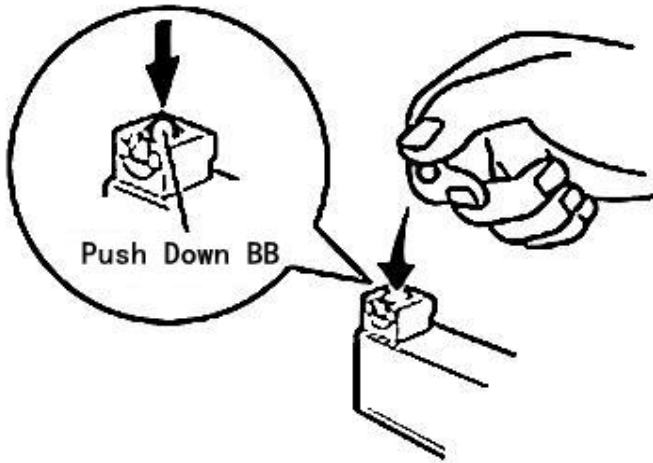

The magazine is capable of containing 30 bullets.

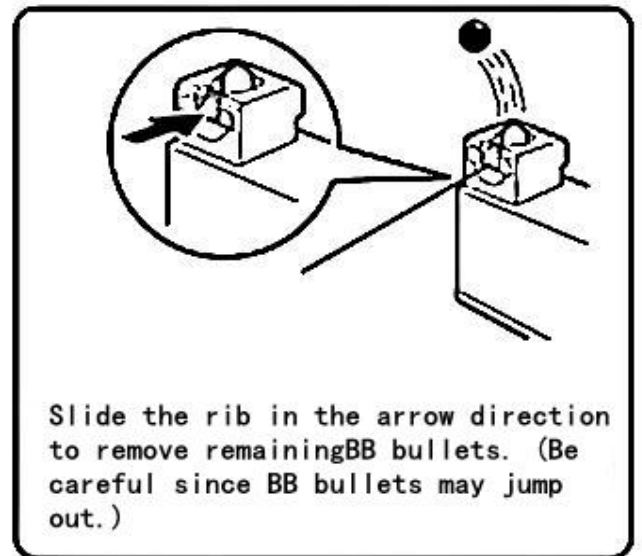

2. Push down the BB follower and feed bullets one by one.

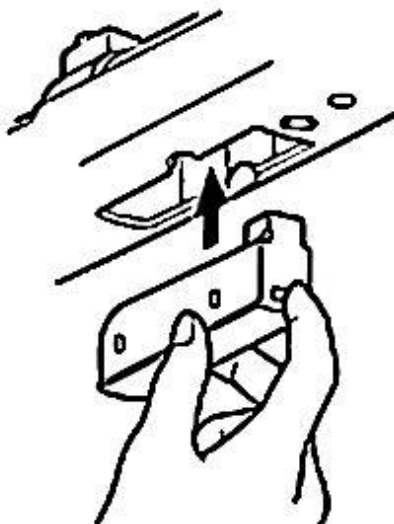

3. Always set the magazine upwardly. Hold the magazine horizontally and push it from below until it clicks.

4-OPERATION

1. Put up the bolt handle and pull until it clicks.

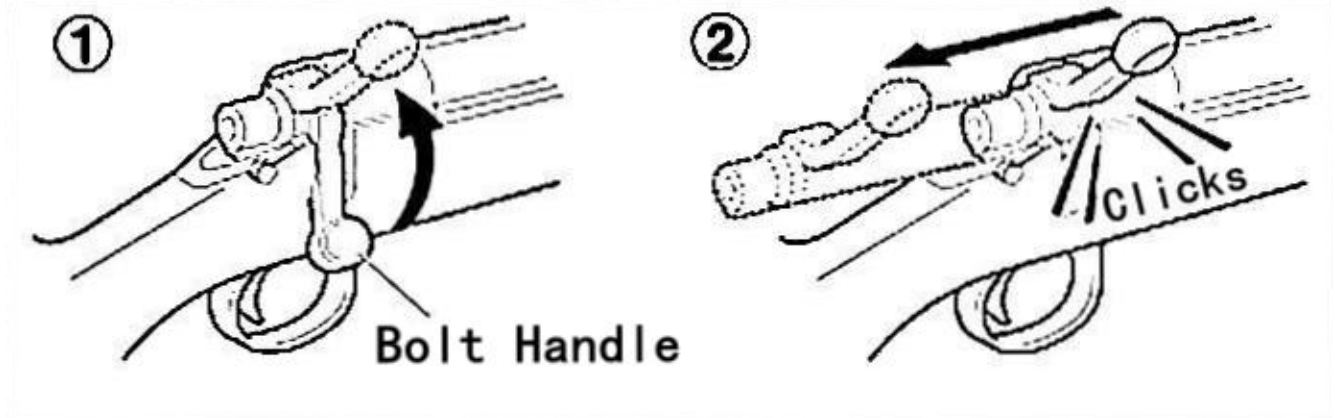

2. Return the bolt handle and put down (If the bolt handle is not put down completely, you can not pull the trigger).

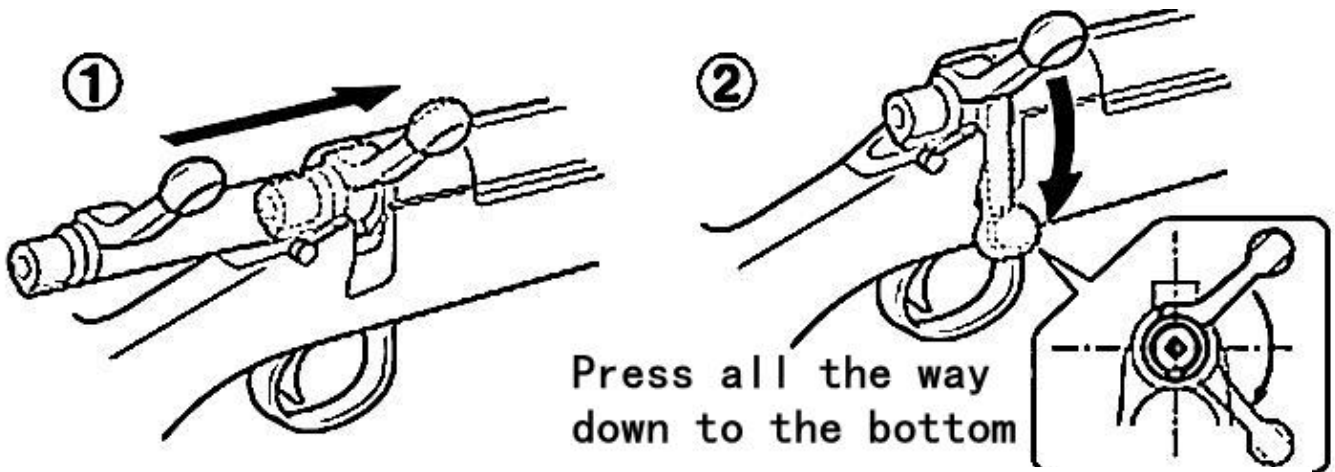

3. Set the safety lever to "F" to release safety.

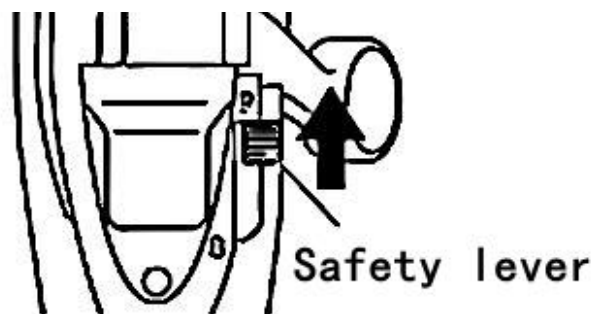

4. Pull the trigger.

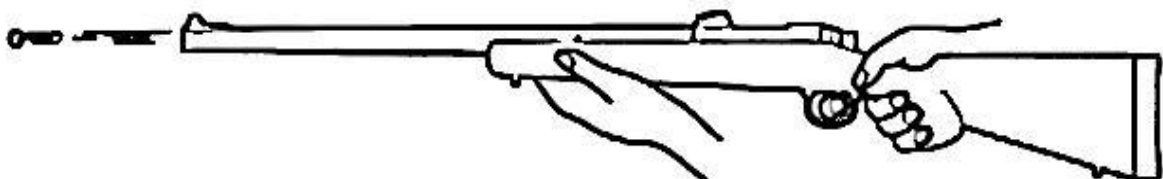

5-HOP-UP ADJUSTMENT

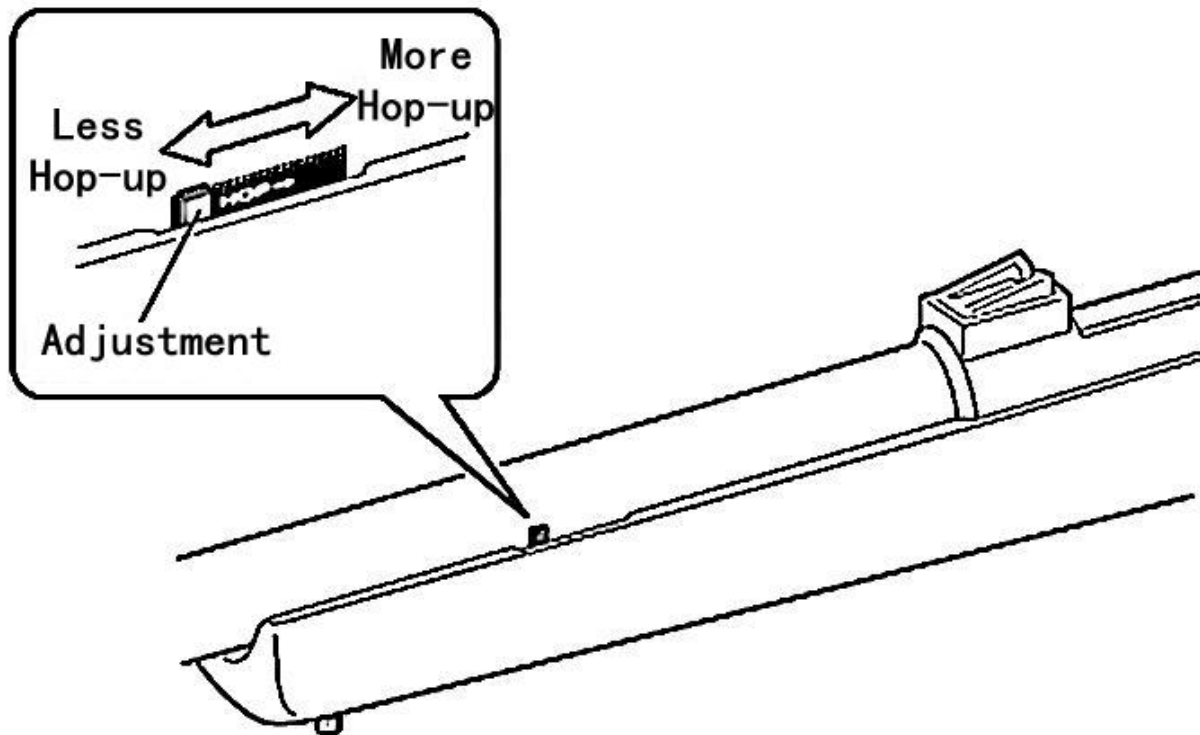

- Moving the lever too much towards HOP causes bullets to clog.
- If bullet clogging occurs, immediately stop firing the gun, return the hop adjustment lever to the Release position and remove clogging bullets using the cleaning rod.
- Never use used and dirty bullets.
- Turning excessively adversely affects the trajectory, So, stop turning the hop adjustment lever when bullets fly horizontally.
- The hop up dial can only be turned a certain amount, Turning it too much will damage it.



WARNING 警告



Certified shooting safety goggles
合格的發射防護眼鏡。

Wear protective eye wear & face mask when using air soft airguns.

當使用汽彈槍時，請戴上防彈眼鏡和面具。

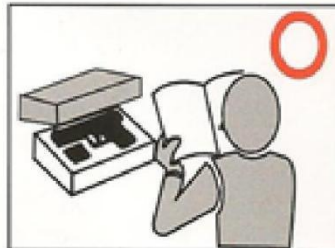

Read and understand the operating and safety manual before using your air soft airguns.

在使用汽彈槍前，請先閱讀和理解操作安全手冊。



Do not look directly into the gun barrel to avoid accidental discharge of BB.

不要直接地看槍管，避免BB彈意外發射。

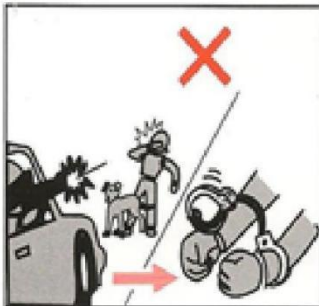

You may be punished if you damage public or personal properties or injure a person or animal even if you are shooting for a practical joke. Always observe manners and enjoy healthy sport shooting.

如果你損害公共的或私人的財產，或者傷害人或動物，即使你是在進行射擊實踐遊戲，你也會受到懲罰。請始終遵守規矩，享受有益健康的運動射擊。



Never aim or shoot a person or animal as the target. Always attach the protective plug to the muzzle, except when you are ready to shoot a target.

不可把人或動物當作目標瞄準或射擊。始終系上槍口的防護塞，除非你準備去射擊一個明確的目標。



This air gun is manufactured under consideration of appropriate performance and operability. Disassembling or modifying the gun may generate danger or adversely affect the performance. So avoid disassembling or modifying the air gun.

該槍是根據適當的性能和操作性而製造的。拆除或改裝槍可能產生危險或者逆反操作。因此要避免拆除或改裝該槍。